

# StormPro MAXX

## OPERATION MANUAL

Dated: 1/28/08

Supersedes: None

Document No.: SPMAXX-OM

Page 1 of 8

# StormPro<sup>®</sup> MAXX



### Introduction

This manual has been specially created to give you a thorough understanding of your inverter and its optimum use. **Do spare some time to read it carefully.** In case you should need help at any time, please feel free to contact or mail us at: [residentialproducts@metropolitanind.com](mailto:residentialproducts@metropolitanind.com) Any suggestions, comments are welcome.

Thank you for purchasing your StormPro product. To help insure years of trouble free operation, please read the following manual carefully.

### Knowing Your Inverter

Reasonable care and safe methods should be practiced. Check local codes and requirements before installation. This manual contains important information for the safe use of this product. Read this manual completely before using this product and refer to it often for continued safe product use. **DO NOT THROW AWAY OR LOSE THIS MANUAL.** Keep it in a safe place so that you may refer to it when needed.

### WARNING

Always disconnect the Unit from the receptacle power source and battery before handling or making any adjustments to the system.

#### Battery Backup Warning:

1. Risk of electrical shock this Unit has not been investigated for use in outdoor areas.

2. Risk of electrical shock connect only to a properly grounded, three pronged grounding type receptacle. Under any circumstances do not remove the grounding prong from the power cord.

3. Do not smoke, use sparkable electrical devices or open flame when working on this unit!

4. Do not install Unit in locations classified as hazardous per N.E.C., ANSI/NFPA 70 - 1999.

**FAILURE TO HEED ABOVE CAUTIONS COULD RESULT IN INJURY OR DEATH.**

The StormPro Back Up System is only to be used with the StormPro Pump supplied with the Unit. Using anything other than the Pump supplied with the system will cause damage to the Unit and void the warranty.

### In The Box

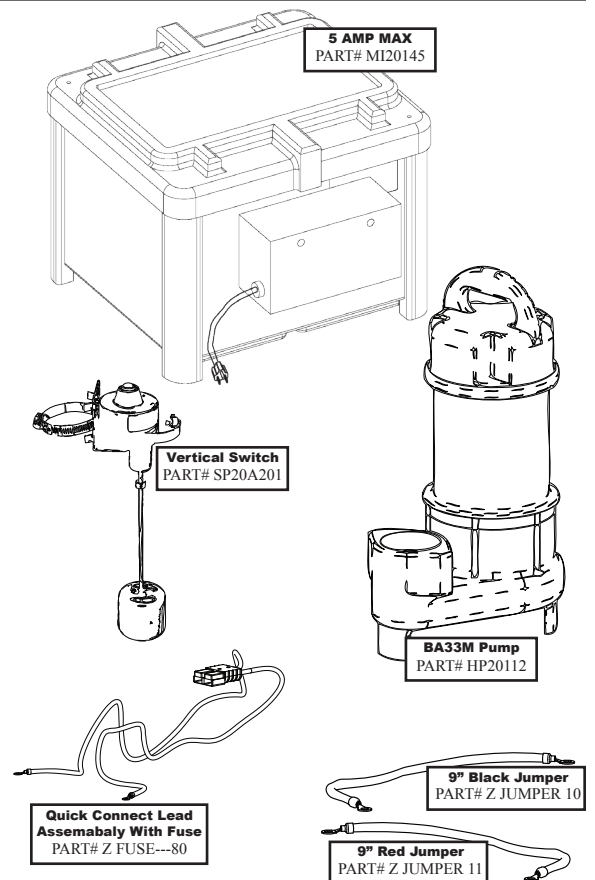

### Tools Needed

A pipe wrench, pliers, adjustable wrench, and screwdriver will be needed.

### Battery Requirements

Your Unit operates on 12VDC battery power when in the power fail mode, a UL recognized deep cycle marine battery should be used.

#### We recommend:

Metropolitan Industries  
Power + Battery  
Model# 27-AGM LW 20104  
Factory Tel: 800-323-1665

### Installation Instructions

1. Remove the lid on the battery enclosure and place the lower half of the battery enclosure with the Unit in a suitable place where a 120V three prong outlet is within reach of the receptacle power cord, and where water will not drip or splash on the Unit. It is also important to make sure that the fan inlets on each side of the battery back-up enclosure are free from obstructions. It is also recommended that the Unit be placed on a board or cinder block to keep it off the moist floor and free from debris.

2. After the battery box has been put in a suitable location the battery can be installed.

A battery can present a risk of severe burns and injury from high short circuit current. The following precautions should be observed when working on batteries.

1. Remove watches, rings, or other metal objects.
2. Use tools with insulated handles.
3. Do not lay tools or metal parts on top of batteries.

After taking the above precautions, Stand at the front of the battery box and lower the 12V battery into the enclosure with the terminals facing the front of the unit as shown in (figure C SINGLE BATTERY pg 3)

Now that the battery has been installed correctly . With the Unit unplugged Install the fuse link cable with quick connector on to the battery (before plugging into head unit see figure. A connect black to neg(-) red to pos(+)) Make sure all battery connections are properly tightened to 75 inch pounds.

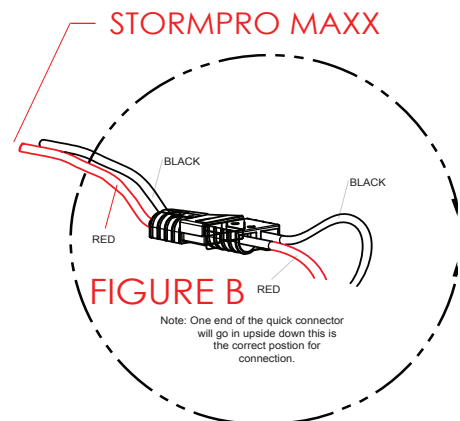
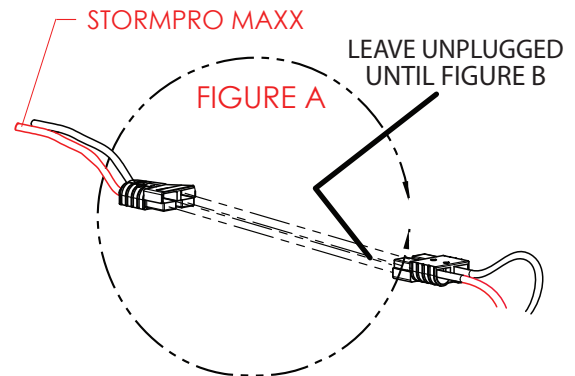

After connecting securely, plug unit into 120 v outlet **at this point you are ready to connect the two ends of the quick connector together. (see figure B)** Then place the battery box cover back on the unit. At this time you may plug the high efficiency pump supplied with the System into the back of the piggyback plug on the Unit.

**Note: For two batteries see diagram labeled D Dual Battery on page 4 repeat steps on figures A and B also)**

**DO NOT PLUG ANY OTHER PUMP THAN THE STORMPRO MODEL#BA-33V PUMP SUPPLIED WITH THE SYSTEM INTO THE POWER SUPPLY. DOING SO WILL VOID THE WARRANTY!**

#### FUNCTIONS AND LIGHTS:

The GREEN Power On indicator light should remain on as long as standard line power is available.

1. Flashing GREEN light is normal and indicates that

# C

SINGLE  
BATTERY

STEP 1



**LEAVE UNPLUGGED**  
UNTIL CONNECTING BATTERIES  
AND PLUG INTO 120 V OUTLET

STEP 2



AFTER CONNECTING ALL BATTERIES  
TERMINALS SECURELY, PLUG UNIT  
INTO 120 V OUTLET AT THIS POINT  
YOU ARE READY TO  
CONNECT THE QUICK  
CONNECTORS

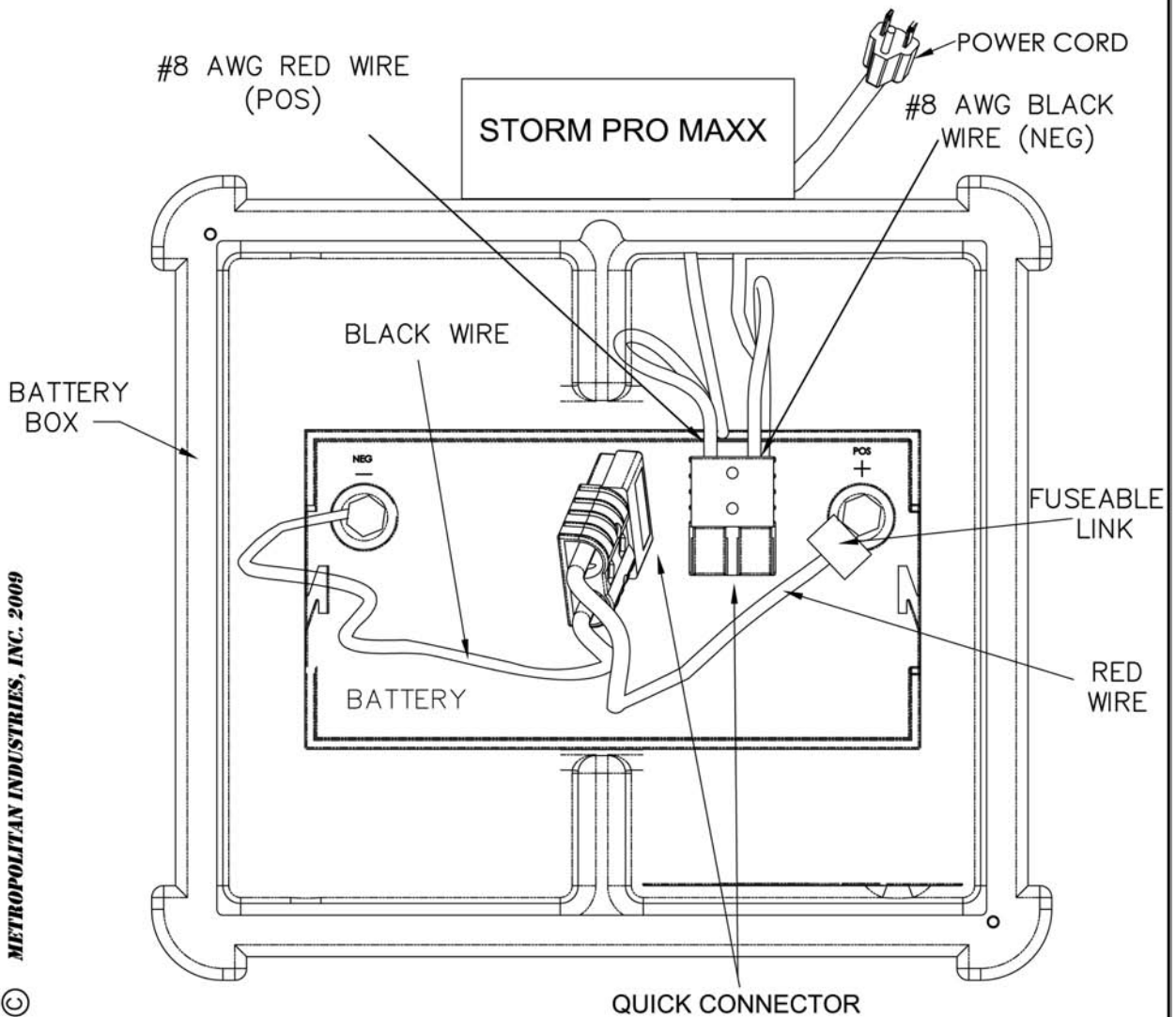

METROPOLITAN INDUSTRIES, INC. 2009



MADE IN THE U.S.A.

# D

DUAL  
BATTERY

STEP 1



**LEAVE UNPLUGGED**  
UNTIL CONNECTING BATTERIES  
AND PLUG INTO 120 V OUTLET

STEP 2



AFTER CONNECTING ALL BATTERIES  
TERMINALS SECURELY, PLUG UNIT  
INTO 120 V OUTLET AT THIS POINT  
YOU ARE READY TO  
CONNECT THE QUICK  
CONNECTORS

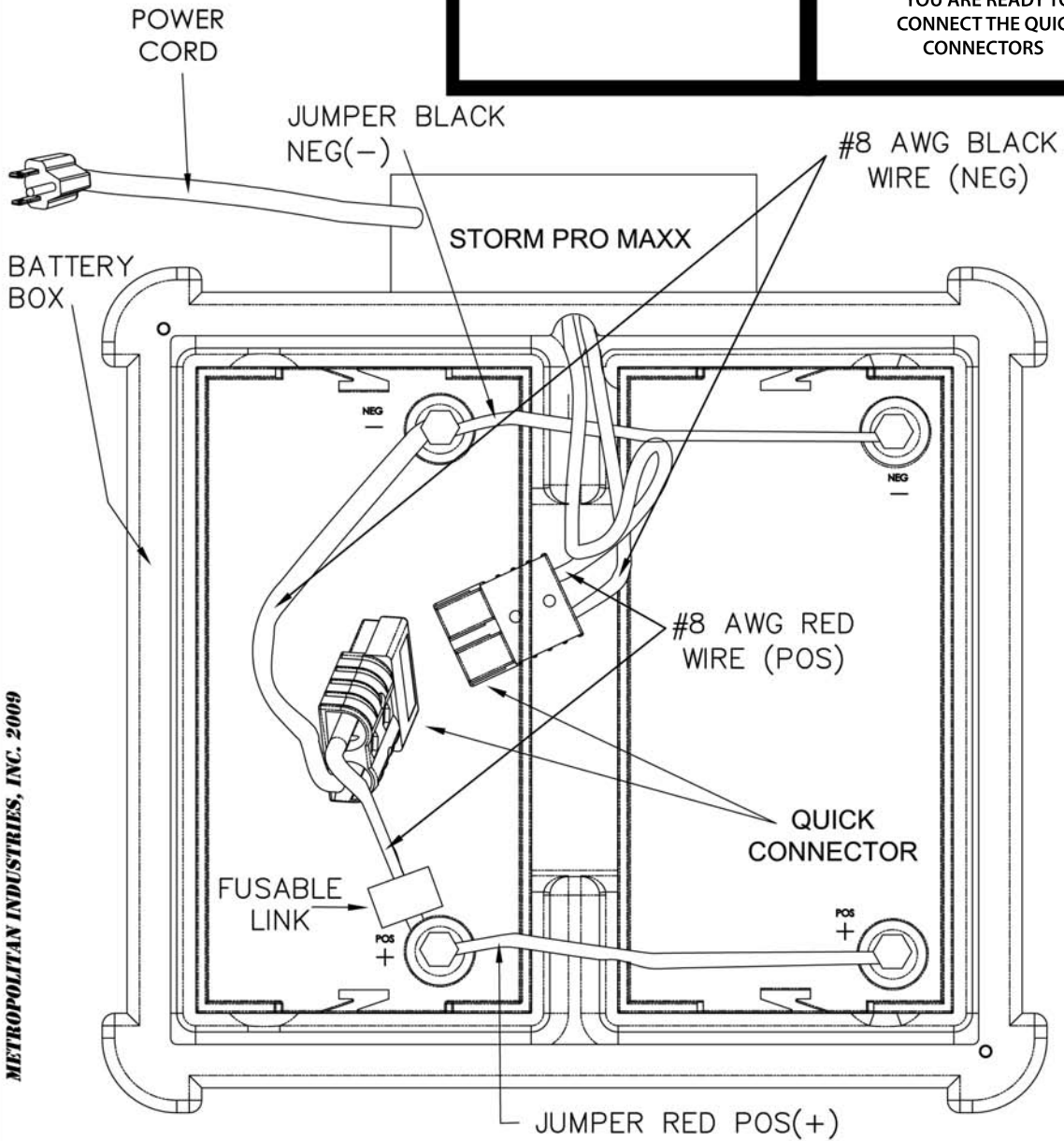

METROPOLITAN INDUSTRIES, INC. 2009

© MADE IN THE U.S.A.

the battery is fully charged.

- The green light should remain flashing indicating that the system is ready for operation.

2. Continuously lit GREEN light indicates that the battery is charging.

- The battery is charging due to normal discharge.
- The system has run off of the battery and the power supply is recharging the battery to its optimum level.

**The RED Inverter/Battery On indicator light should only appear when the power is out or there is a problem with the system.**

1. Single flashing RED light indicates a low battery.
  - The battery most likely needs to be replaced. Contact your installer or Metropolitan Industries for a compatible replacement battery.
2. Double Flashing RED light indicates the unit has overloaded.
  - The pump plugged into the power supply exceeds the power supply's rating of 5 amps. Only use a Stormpro 1/3HP pump Model # BA-33V with the StormPro power supply.
  - The pump is malfunctioning and is running at a higher amperage than normal. Most likely your pump will need to be repaired or replaced. Contact your installer or Metropolitan Industries for further assistance

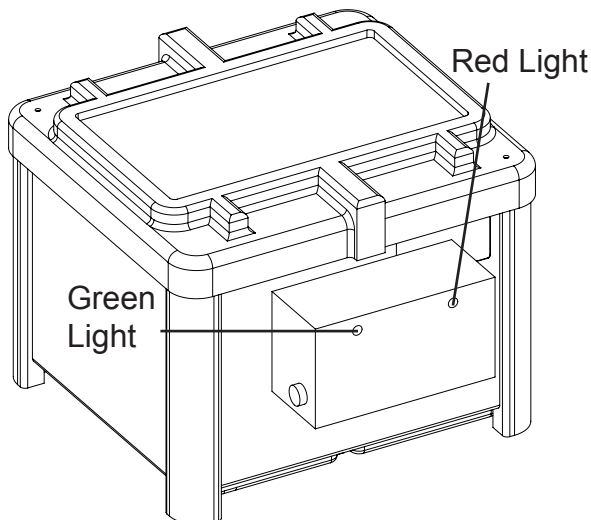

3. If battery voltage falls below a usable charge, **PUMP WILL STOP:**

- **Power loss (inverter on) light OFF**
- **Battery charging light FLASH**
- **Fully charged light OFF**

### Installation Diagram

Note: The StormPro backup system and existing primary pump must be plugged into separate dedicated outlets.

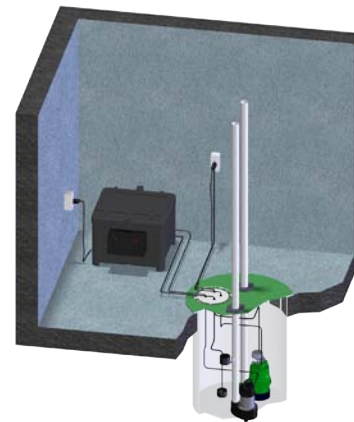

### Installing the Backup Pump

Sump pump ON level must be lower than the backup pump ON level. Set the backup pump switch higher than the primary switch.

1. Place the pump into the pit. Secure the discharge piping and attach the switch to the pipe. Make sure the switch ON level is at least 4 inches below the top of your pit and it is set at a level higher than the primary switch's ON level. Once in place, tighten the switch clamp securely to the pipe.
2. Once the switch is set in place and the discharge piping is properly installed, you can piggy back plug the pump and the switch into the receptacle located on the StormPro power supply. Then plug the power supply into the wall outlet.

**Switch  
Clamped  
Securely  
To  
Pipe**



3. Test run your system on AC power by activating the switch, then unplug the power supply from the electrical outlet and test the pump on DC power by activating the switch. Be sure to plug the power unit plug back into the wall outlet.
4. After a extended period of power lose, your battery voltage will not be adequate to run your pump. However, battery voltage may recover and allow brief periods of operation.

### Testing

To test the Unit simply unplug it from the receptacle add water to sump until pump pumps sump down. Only run the Pump supplied with the Battery Back-Up System for a few cycles. You can repeat this if you wish but it is not necessary. If the Unit works the first time it is sure to work time and time again. Be sure that you remember to plug the Unit back into the receptacle after you have completed the test.

NOTE: If while testing the Unit the Pump does not turn on, the following steps should be taken:

1. Check the charger and inverter lights to see if they are on.
2. Check the circuit breaker.
3. Plug the Pump you have plugged into the Unit directly into a live building receptacle. If the Pump runs, recheck all the battery connections, and battery voltage.
4. Check sump water level to see that Pump is being required to run.
5. If the above items have been thoroughly checked and your pump will still not run when plugged into the Unit, remove the battery from the battery box as described in the assembly instructions and return the Unit to the place of purchase for repair or replacement.

### Battery Maintenance

1. If your are using the Metropolitan Industries Power + AGM maintenance free Battery you do not need to perform any maintenance to your battery/batteries for all other batteries refer to the manufacturer recommended battery maintenance section.
2. Maintenance or replacement of batteries should be performed or supervised by personnel knowledgeable of batteries and the required precautions.

### Replacing Battery

1. Wear full eye protection and protective clothing.
2. When replacing the battery/batteries, use the same type and size battery/batteries; see battery requirements for ordering information. (Page 1)
3. CAUTION-The electrolyte is a dilute sulfuric acid that is harmful to the skin and eyes. It is electrically conductive and corrosive. The following procedures should be observed:
  - Use tools with insulated handles
  - Do not lay tools or metal objects on top of the batteries
1. CAUTION-Do not dispose of battery in a fire. The battery may explode.
2. CAUTION-A battery can present a risk of severe burn and injury from high short circuit current. The following precautions should be observed when working on batteries.
3. CAUTION-Do not open or mutilate the battery. Released electrolyte is harmful to the skin and eyes. It may be toxic.
4. CAUTION-The electrolyte is a dilute sulfuric acid that is harmful to the skin and eyes. It is electrically conductive and corrosive. The following procedures should be observed:



- If electrolyte contacts the skin, wash it off immediately.
  - If electrolyte contacts the eyes, flush thoroughly and immediately with water. Seek medical attention.
  - Spilled electrolyte should be washed down with a suitable acid neutralizing agent. A common practice is to use a solution of approximately one pound (500 grams) bicarbonate of soda to approximately one gallon (4 liters) of water. The bicarbonate of soda solution be added until the evidence of reaction (foaming) has ceased. The resulting liquid should be flushed with water and the area dried.
5. CAUTION- Lead acid batteries can present a risk of fire because they generate hydrogen gas. The following procedures should be followed:
- DO NOT SMOKE when near batteries.
  - DO NOT cause flame or spark in battery area.
  - Discharge static electricity from body before touching batteries by first touching a grounded metal surface.
6. If not using Metropolitan Industries, Power + batteries see battery manufactures installation, replacement, maintenance, and safety instructions.

Your Unit has been designed to be virtually maintenance free. Just make sure it is kept clean and dry and that the Unit is periodically tested.

### Battery Safety

1. CAUTION-Do not dispose of battery in a fire. The battery may explode.
2. CAUTION-A battery can present a risk of severe burn and injury from high short circuit current. The following precautions should be observed when working on batteries.
3. CAUTION-Do not open or mutilate the battery. Released electrolyte is harmful to the skin and eyes. It may be toxic.

4. CAUTION-The electrolyte is a dilute sulfuric acid that is harmful to the skin and eyes. It is electrically conductive and corrosive. The following procedures should be observed:
  - If electrolyte contacts the skin, wash it off immediately.
  - If electrolyte contacts the eyes, flush thoroughly and immediately with water. Seek medical attention.
  - Spilled electrolyte should be washed down with a suitable acid neutralizing agent. A common practice is to use a solution of approximately one pound (500 grams) bicarbonate of soda to approximately one gallon (4 liters) of water. The bicarbonate of soda solution be added until the evidence of reaction (foaming) has ceased. The resulting liquid should be flushed with water and the area dried.
5. CAUTION- Lead acid batteries can present a risk of fire because they generate hydrogen gas. The following procedures should be followed:

### Warranty is VOID, if...

1. Power cord has been cut or the grounding prong has been removed.
2. Unit has been used in an outdoor application.
3. Batteries not meeting the above specifications have been used.
4. Unit has been submerged in water.
5. Unit has been tampered with in any manor not described in the above instructions.
6. Unit has been disassembled by customer.
7. Unit has been applied to products exceeding the maximum capacity of the Unit.
8. Unit has been applied to the wrong voltage.
9. The StormPro Back-Up System is used with any other pump than the StormPro BA-33V 1/3hp pump.



## WARRANTY

1. Coverage and Term. Metropolitan Industries, Inc. (“**Metropolitan**”) warrants to the original purchaser (the “Buyer”) of each Metropolitan product (the “product”), that any part thereof which proves to be defective in material or workmanship within one (1) year from date of installation or 18 months from the date of manufacture, whichever comes first, will be replaced at no charge with a new or remanufactured part, F.O.B. factory. Buyer shall be responsible for all freight charges and all costs of field labor or other charges incurred in the removal and/or reinstallation of any product, part or component thereof.
2. Exclusions. **THE WARRANTY IS SUBJECT TO THE FOLLOWING CONDITIONS AND EXCLUSIONS:**
  - (a) The Warranty excludes products or workmanship which becomes defective as a result of: (i) earthquake, fire, storms, the elements or any other acts of God; (ii) normal wear and tear from use; (iii) accident, misuse, abuse or neglect ; (iv) modifications made by Buyer or any third party, other than **Metropolitan**; and (v) Buyer’s failure to properly install, maintain, service and/or operate the product under normal conditions and according to manufacturer’s instructions.
  - (b) **Metropolitan** shall not be responsible for, and the Warranty shall not cover, extended damage which occurs because of Buyer’s failure to notify **Metropolitan** promptly in writing of apparent defects.
  - (c) Any part or component designated as manufactured by anyone other than **Metropolitan** shall be covered only by the express warranty of the manufacturer thereof.
  - (d) The Warranty shall lapse upon Buyer’s failure to fully comply with the terms and conditions of its contract with **Metropolitan**, including Buyer’s failure to pay the purchase price for the product or any portion thereof. Buyer’s subsequent compliance with the terms and conditions of any such contract, will not cause the term of the Warranty to extend beyond the time period set forth above.
  - (e) No actions taken by **Metropolitan** to correct a defect in a product shall extend the Warranty beyond the period set forth above. **Metropolitan** shall not be obligated to remedy any defect, where otherwise required pursuant to the Warranty unless and until Buyer notifies **Metropolitan** in writing of the defect and then only if such notification is made prior to the expiration of the period set forth above.
3. Process of Claims and Repairs. **Metropolitan** agrees that if the product or any part or component thereof shall fail to conform to the terms of this Warranty, **Metropolitan** shall replace such nonconforming product, part or component at the original point of delivery and furnish instruction for its disposition. Any transportation charges involved in such disposition and all costs of field labor or other charges incurred in the removal and/or reinstallation of any product, part or component thereof shall be the responsibility of Buyer.
4. Limitation on Liability. Notwithstanding any provision to the contrary, **Metropolitan’s** entire liability under this Warranty shall not in the aggregate exceed, and Buyer’s exclusive and sole remedies are, to the extent permitted by law, shall be to secure replacement of the defective product. **UNDER NO CIRCUMSTANCES SHALL METROPOLITAN BE LIABLE UNDER THE WARRANTY FOR ANY INDIRECT, PUNITIVE, SPECIAL, EXEMPLARY, CONSEQUENTIAL OR INCIDENTAL DAMAGES (INCLUDING LOST PROFITS, REVENUE, USE OR ECONOMIC ADVANTAGE).**
5. Express Waiver of Any Other Warranties. **THE EXPRESS WARRANTY SET FORTH IN THIS WRITTEN WARRANTY IS THE ONLY WARRANTY MADE BY METROPOLITAN, OR ANY OTHER PARTY, IN CONNECTION WITH ANY PRODUCT PURCHASED FROM METROPOLITAN. NEITHER METROPOLITAN, NOR ANY OTHER PARTY, MAKES ANY OTHER EXPRESS OR IMPLIED WARRANTY WHICH IS NOT SET FORTH HEREIN, AND METROPOLITAN HEREBY DISCLAIMS AND BUYER HEREBY WAIVES ALL IMPLIED WARRANTIES, INCLUDING THE IMPLIED WARRANTY OF MERCHANTABILITY AND THE IMPLIED WARRANTY OF FITNESS FOR A PARTICULAR PURPOSE.**
6. Not Transferable. The Warranty may not be transferred and shall be void on the sale or other transfer of the product.
7. Products and Warranty Subject to Change. **Metropolitan** reserves the right to make revisions to its products and their specifications, and to revise this Warranty and related information without notice.

Register your product at

[www.sumpro.com](http://www.sumpro.com)